



PATKOL
Public Company Limited

Ice Maker



PATENT PENDING

Scale Ice

Features

- Ice production rate : 2,500 - 5,000 kg / 24 hr
- Dry-Frozen ice ,approximate temp. -3°C
- Stainless steel evaporator drum
- Frame construction in stainless steel
- Hygienic ice produced
- Easy to operate and maintainance
- Freon and Ammonia refrigerant available
- PLC remote control panel

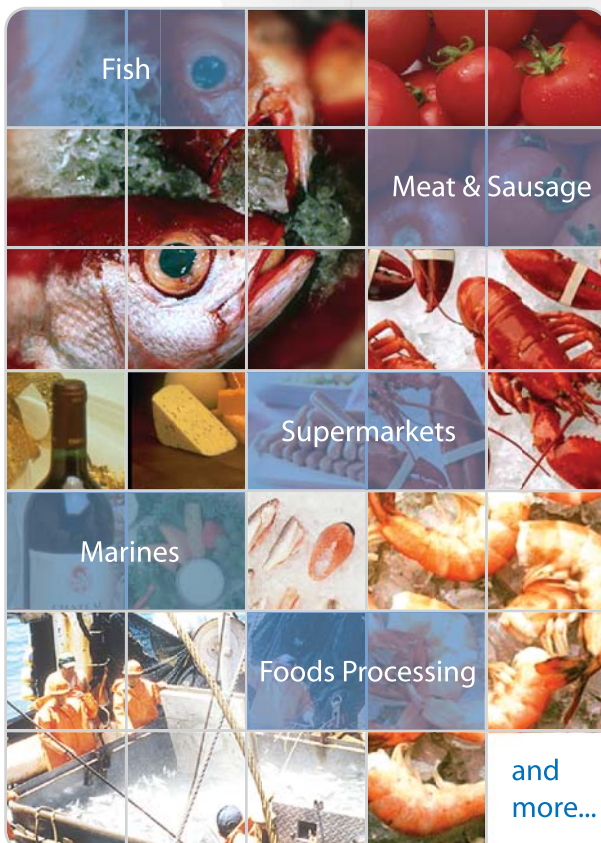

TRD/ISI-PI/2020/04/04

Technical Data

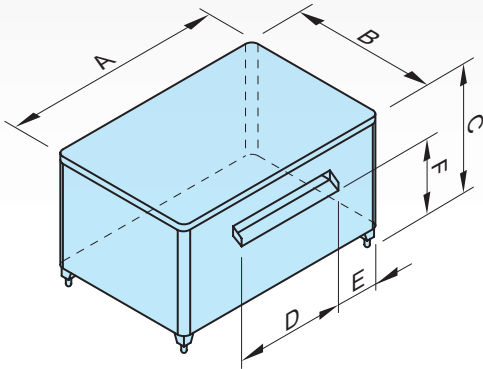

SI-2500

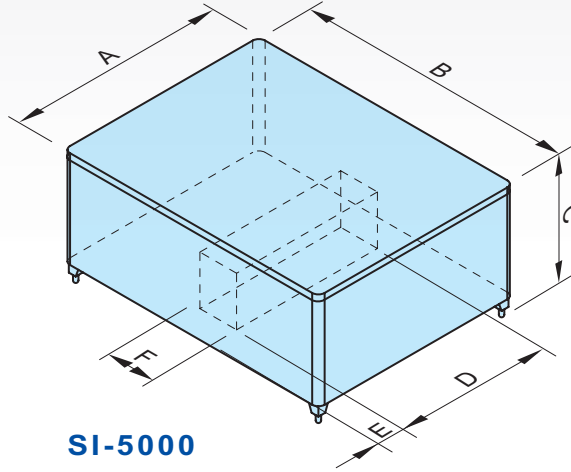

SI-5000



Scale Ice



Control Panel



Ice Bin

Models	Ice Capacity kg / 24 hr	Refrigeration required (kw)	Dimension (mm)						Weight (kg)
			A	B	C	D	E	F	
SI-2500	2,500	18	1410	800	840	750	400	560	380
SI-5000	5,000	36	1410	1840	840	1020	200	270	800

Standard rating condition

- 30°C water entering , 35°C ambient
- Ice thickness 0.5 - 1.5 mm.
- Evaporating temperature -24°C
- Standard electrical 380 V , 3 Ph , 50 Hz
- Water supply 1-2 bar

Note :

- Consult factory for sea-water application
- R717 for use with a recirculated system
- This unit exclude compressor and condensing unit

Make up water correction factors

Make up water temp. (°C)	5	10	15	20	25	30	35
Ice Multipliers	1.22	1.18	1.13	1.09	1.04	1	0.96

Refrigerant correction factors

Refrigerant	R404A	R22	R717
Ice Multipliers	0.95	1	1.22

Evaporating temp. correction factors

Evaporating temp. (°C)	-32	-28	-24	-20
Ice Multipliers	1.06	1.03	1	0.87

Remark : Design and specifications subject to change without notice.

Quality With Service



PATKOL
Public Company Limited

348 Chalermprakiat Rama 9 Road, Nongbon, Pravate, Bangkok 10250, THAILAND
 Tel : (66) 2328 1032-49 Fax : (66) 2328 1245, (66) 2328 1058
 website : www.patkol.com e-mail : svc@patkol.com, sales@patkol.com