



Mealstream RD401

The RD401 is an all electric convection and microwave combination oven with fully variable microwave power, offering excellent results for any call order menu.

Ideally suited for kitchens where space is at a premium.

- Microwave combination mode reduces cooking times by up to 5 times. e.g. Rack of Lamb (10 oz) – 4 min.
- Easy to clean controls.
- User friendly rotary controls.
- Fully variable microwave power (can be changed during cooking cycle) and convection heat temperature.
- Quick pre-heat time (max 15 min).
- Low loss insulated cavity for energy efficiency.
- Quality assured BS EN ISO 9001 accreditation and CE marked.

Mealstream RD401

Technical Specifications

Power output	Microwave @ 100%	700 Watts, (IEC 705 Rating)
	Convected heat	3000 Watts
	Combination mode CD2	700 Watts microwave + 1500 Watts convected heat
	Combination mode XD2	700 Watts microwave + 3000 Watts convected heat
Power input	CD2 3.12kW XD2 4.60kW	
Weight	45kg Nett 55kg Gross Packed	
Electrical supply	240V 50Hz Single Phase or 220V 50Hz Single Phase 60Hz available for marine specification, please ask for details	
Dimensions mm (HxWxD)	Internal	315 x 330 x 330
	External	527 x 545 x 555
Capacity	34.3 Litres	
Microwave power levels	Fully variable between 0% and 100%	
Magnetrons	One	
Safety interlocks	Three	
Distribution system	Turntable	
Convection heat settings	Fully variable between 0°C and 275°C	
Timer	Up to 30 mins	
User interface	Rotary controls for convection temperature, microwave power and time	
Construction	Cavity – Vitreous enamel coated steel Casework – 304 Stainless steel	
Safety features	Microwave safety interlocks on door Cavity overheat sensor Magnetron overheat sensor	
Additional information	CD2 moulded 13 Amp plug BS 1363A (UK only) XD2 30 Amp cable with plug BS 4343	
Order reference	13 Amp	RMC100345CD2 (240V-50Hz) RMC100325CD2 (220V-50Hz)
	30 Amp	RMC100345XD2 (240V-50Hz) RMC100325XD2 (220V-50Hz)

Installation requirements

- Away from major heat sources.
- Place on a flat surface that is level, strong and stable.
- Allow a minimum of 50mm clearance at the rear of the oven and to either side for air to circulate freely.
- Allow 150mm clearance above the oven for hot air to escape.
- Do not stack the oven directly on top of another. Use a separate shelf or double tiered stand (for stand and trolley, price on application).
- Allow sufficient clearance in front of the oven for the door to open fully (393mm).
- If circuit breakers are in use, ensure Type C units are fitted.

DEALER

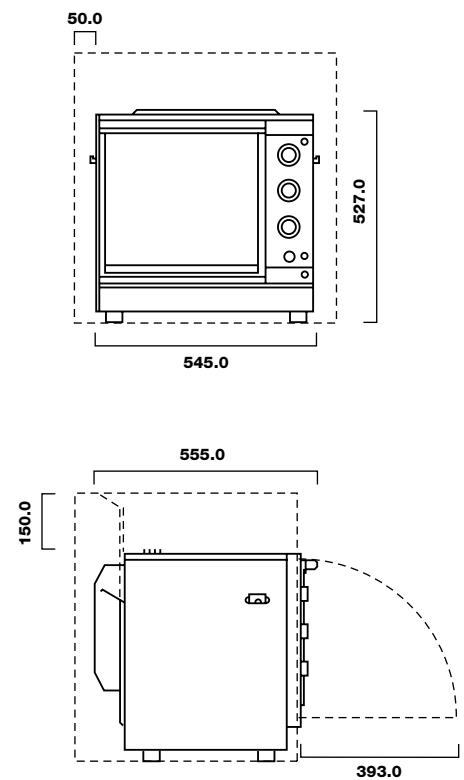

All dimensions in mm



For further information on Merrychef products and services or advice on which machine suits you best please contact:

Merrychef Limited Station Road West
Ash Vale Aldershot Hampshire GU12 5XA
United Kingdom

Telephone: +44 (0)1252 371000

Fax: +44 (0)1252 371007

Email: marketing@merrychef.co.uk

Web: www.merrychef.co.uk



ASSOCIATE MEMBER



Merrychef continually strives to improve its products and reserves the right to make any improvements or change the specifications of any of its products at any time.

© Merrychef Limited. All rights reserved.

REF: 32Z3375. ISSUE 2.